



Undercounter ice maker up to 104 kg - Granular system

Hotel	████████████████████
Restaurant	████████████████████
Fast food	████████████████████
Bar	████████████████████
Disco	████████████████████
Fish market	████████████████████
Supermarket	████████████████████
Medical & SPA	████████████████████
Industry	████████████████████

► Position n°



► Features & Plus

- Granular ice - 80-82% dry
- 1l (water) - 1kg (ice) - only Air cooled
- AISI 304 SS Scotch Brite finish
- Tropical class +43°C
- Adjustable Stainless Steel feet
- Removable and cleanable air filter
- AISI 304 SS evaporator
- Air or water cooling system
- Easy cleanable internal rounded surfaces
- HCFC-Free insulated storage
- Dust-proof water basin
- RoHS Free
- Disappearing insulated door
- Electromechanical operation
- ON-OFF rocker switch
- Automatic water charge
- Standard and special voltages



AISI 304 SS Scotch Brite finish



Removable and cleanable air filter



AISI 304 SS evaporator



Dust-proof water basin



Disappearing insulated door

► Prod. 24h

🌡️	Air temp.		Water temp.		Kg	Lbs
	10° C	50° F	10° C	50° F		
	21° C	70° F	15° C	60° F		
					104	229
					95	209

2 Years Warranty

subject to limitations

► Certifications available for this model



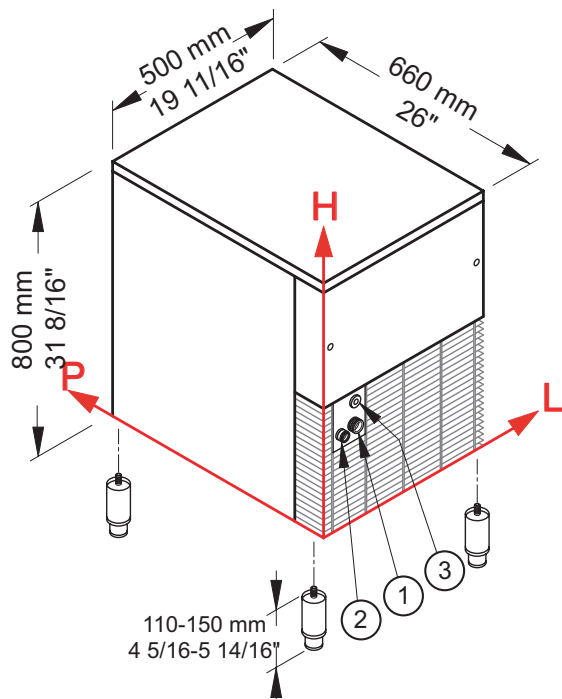

Ice Flakes

GB 903**Undercounter ice maker up to 104 kg - Granular system****► Working conditions**

- Location: **Indoor**

	Min	Max
Ambient temperature	+10° C / +50° F	+43° C / 110° F
Water temperature	+3° C / +37° F	+32° C / +90° F
Voltage	-10%	+10%
Water inlet pressure	1bar (14 psi)	6bar (84 psi)

► Performances

	Air temperature	Water temperature	Water temperature					
			10° C	50° F	15° C	60° F	21° C	70° F
	10° C	104 kg						
	50° F	229 lbs						
	21° C		95 kg					
	70° F			209 lbs				
	32° C				81 kg			
	90° F					179 lbs		

► Connections

All measures are referred to the rear bottom-left corner (L-H-Ø)

- ① Water in.: 99 mm / 3 14/16" - 158 mm / 6 4/16" - 3/4"
- ② Water out.: 48 mm / 1 14/16" - 151 mm / 5 15/16" - 24 mm / 15/16"
- ③ Electrical connections: 87 mm / 3 7/16" - 230 mm / 9 1/16"

► Technical information

Production in 24h	95 kg / 209 lbs
Store capacity, up to	30 kg / 66 lbs
Cooling system	A - W
Refrigerant	R404A
Standard voltage	220-240 V ~ 50 Hz
Electrical consumption	550 W
Fuse	10 A
Finish	AISI 304 stainless steel, scotch brite

Water consumption	A: 1 l/kg - 12,0 gal/100 lbs
	W: 6,3 l/kg - 75,5 gal/100 lbs
Sizes (L-P-H mm)	500 - 660 - 800
(L-P-H in)	19 11/16 - 26 - 31 8/16
Sizes with pack (L-P-H mm)	550 - 720 - 990
(L-P-H in)	21 10/16 - 28 6/16 - 39
Net weight	67 kg / 148 lbs
Gross weight	76 kg / 168 lbs

All the technical information need to be considered at the following conditions:

Sizes without feet

Ambient temperature +21° C

Water temperature +15° C

Electrical consumption at +43° C (standard voltage)

Models and specifications are subject to change without notice

**BREMA ICE MAKERS SPA**Via dell'Industria 10,
20020 Villa Cortese (MI), Italytel. +39 0331 434811
fax +39 0331 433833www.bremaice.it
info@bremaice.itBim + Data
download

Installation



We are Brema

